

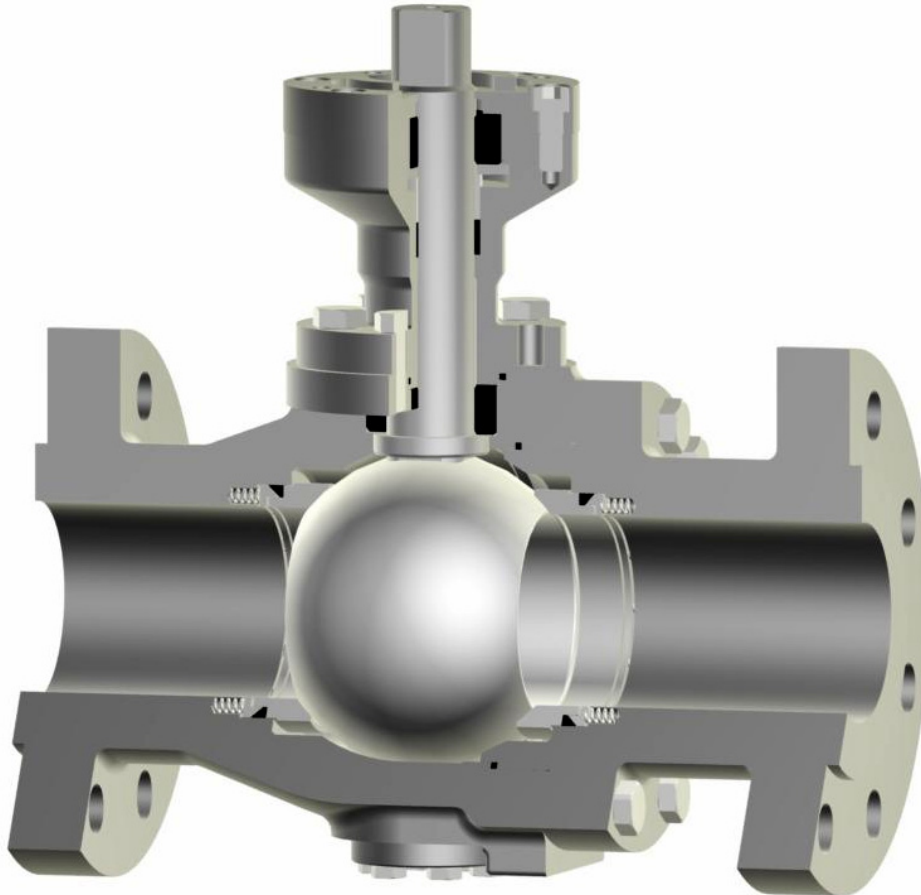

Zwei-Wege Kugelhahn metallisch dichtend Baureihe 14-M



Konstruktionsmerkmale

- ✓ zweiteiliges Gehäuse
- ✓ zapfengelagerte Kugel
- ✓ „Blow out proof“ Schaltbolzen
- ✓ federbelastete Packung
- ✓ federbelastetes Sitzsystem
- ✓ „Fire Safe“ Ausführung optional

Angewendete Normen

- ✓ EN 12516, EN 1983, ISO 5211, AD-2000
- ✓ ASME B16.34, API 608

Einsatzbereich

- ✓ Nennweite 1" bis 24" / DN 25 bis 600
- ✓ Class 150 bis 2500 / PN 10 bis 420
- ✓ -76°F bis +1000°F / -60°C bis +550°C

Zulassungen

- ✓ „TA-Luft“

Prüfnormen

- ✓ EN 12266-1/2
- ✓ API 598



Hauptbauteile

- 1 Körper
- 2 Stutzen
- 4 Druckring
- 5 Kugel
- 6 Schaltbolzen
- 7 Lagerzapfen
- 8 Stützring
- 9 Lagerbuchse
- 10 Lagerdeckel
- 11 Zwischenstück
- 16 Tellerfeder
- 17 Zyl. Druckfeder
- 18 Gehäusedichtung
- 20 Dichtring
- 21 Sitzring
- 23 Gehäusedichtung
- 24 Packung
- 25 Lagerring
- 26 Lagerring
- 27 Gehäusedichtung
- 28 Schraube
- 29 Schraube
- 30 Schraube
- 31 Schraube



Bild 1

Beschreibung

Dieser PERRIN Kugelhahn hat eine zapfengelagerte Kugel in zweigeteiltem Gehäuse. Das federbelastete metallische Sitzsystem und die Packung bewirken gleichbleibende Dichtheit, auch unter kurzfristigen Temperatur- und Druckschwankungen.

Der Kugelhahn wird mit einer Antriebsschnittstelle gemäß ISO 5211 ausgeführt. Schaltbolzenverlängerungen, Schlosseinheiten und Antriebe mit Zubehör sind ohne Betriebsunterbrechungen nachrüstbar.

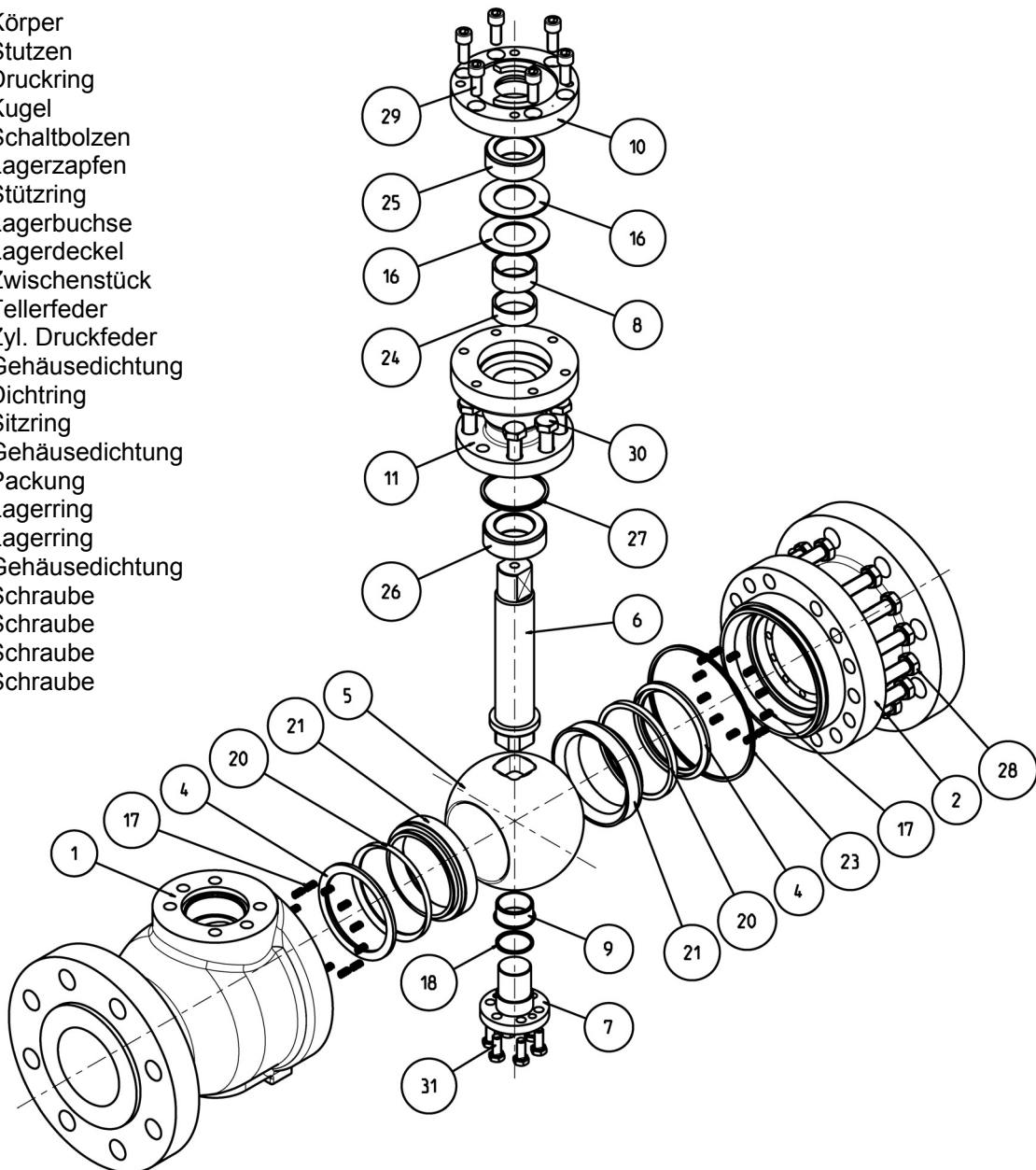
Der Kugelhahn ist antistatisch ausgeführt mit „Blow out proof“ Schaltbolzen. Die Packung und die Dichtungen sind „TA-Luft“ geprüft.



Teilleiste / Werkstoffe



Bild 2

Pos.	Beschreibung	ASME		DIN EN	
		-76°F bis +1000°F	-20°F bis +1000°F	-60°C bis +550°C	-10°C bis +450°C
1	Körper	A351 CF8M	A216 WCB	1.4408 ¹⁾	1.0619
2	Stützen	Typ 316 (bis 2")	A105 (bis 2")	1.4571 (bis 2")	1.0460 (bis 2")
4	Druckring	Typ 316	Typ 316	1.4571	1.4571
5	Kugel	Typ 316 beschichtet A351 CF8M beschichtet	Typ 316 beschichtet A351 CF8M beschichtet	1.4571 beschichtet 1.4408 ¹⁾ beschichtet	1.4571 beschichtet 1.4408 ¹⁾ beschichtet
6	Schaltbolzen	Typ 51 ²⁾ Typ 316	Typ 51 ²⁾ Typ 316	1.4462 ²⁾ 1.4571	1.4462 ²⁾ 1.4571
7	Lagerzapfen	Typ 316 beschichtet	Typ 316 beschichtet	1.4571 beschichtet	1.4571 beschichtet
8	Stützring	Typ 316	Typ 316	1.4571	1.4571
9	Lagerbuchse	Typ 316 beschichtet	Typ 316 beschichtet	1.4571 beschichtet	1.4571 beschichtet
10	Lagerdeckel	Typ 316	A105	1.4571	1.0460
11	Zwischenstück				
16	Tellerfeder ³⁾	Typ 301	AISI 6150	1.4310	1.8159
17	Zyl. Druckfeder	Typ 316	Typ 316	1.4571	1.4571
18	Gehäusedichtung	Graphit	Graphit	Graphit	Graphit
20	Dichtring				
21	Sitzring	Typ 316 beschichtet Typ 51 ²⁾ beschichtet	Typ 316 beschichtet Typ 51 ²⁾ beschichtet	1.4571 beschichtet 1.4462 ²⁾ beschichtet	1.4571 beschichtet 1.4462 ²⁾ beschichtet
23	Gehäusedichtung	Graphit	Graphit	Graphit	Graphit
24	Packung				
25	Lagerring	Kohle	Kohle	Kohle	Kohle
26	Lagerring	Kohle-Antimon	Kohle-Antimon	Kohle-Antimon	Kohle-Antimon
27	Gehäusedichtung	Graphit	Graphit	Graphit	Graphit
28	Schraube	Edelstahl	Edelstahl	Edelstahl	Edelstahl
29	Schraube	Edelstahl	Edelstahl	Edelstahl	Edelstahl
30	Schraube	Edelstahl	Edelstahl	Edelstahl	Edelstahl
31	Schraube	Edelstahl	Edelstahl	Edelstahl	Edelstahl

Tab. 1

1) Temperaturbegrenzung 300°C [576°F] gem. AD-2000 W5, wenn interkristalline Korrosionsbeständigkeit gefordert ist

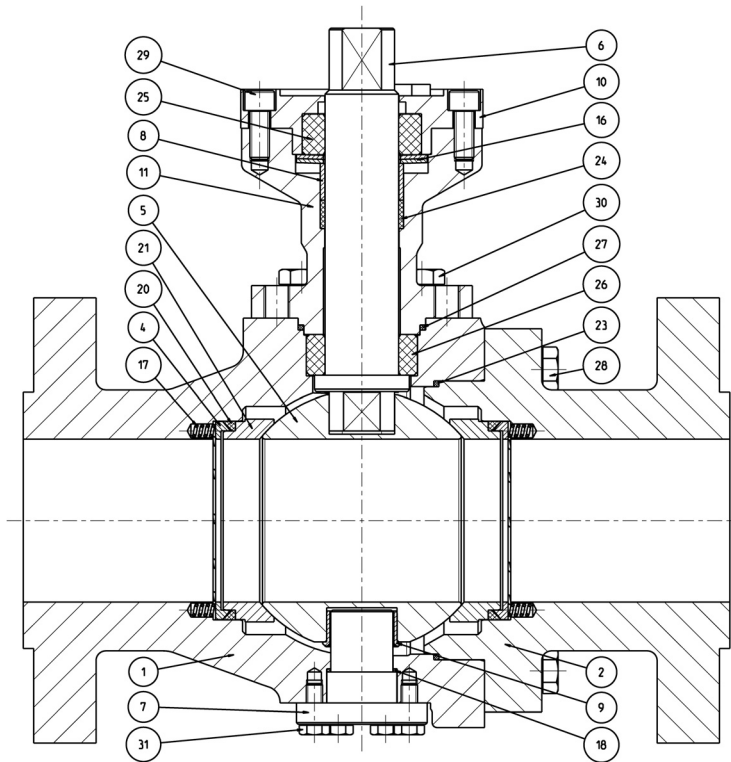
2) Temperaturbegrenzung 280°C [536°F]

3) Werkstoff 2.4668 (Inconel 718) ist gefordert bei Einsatztemperaturen über 200°C [392°F]

4) Werkstoffe für niedrigere / höhere Temperaturen auf Anfrage



Technische Daten

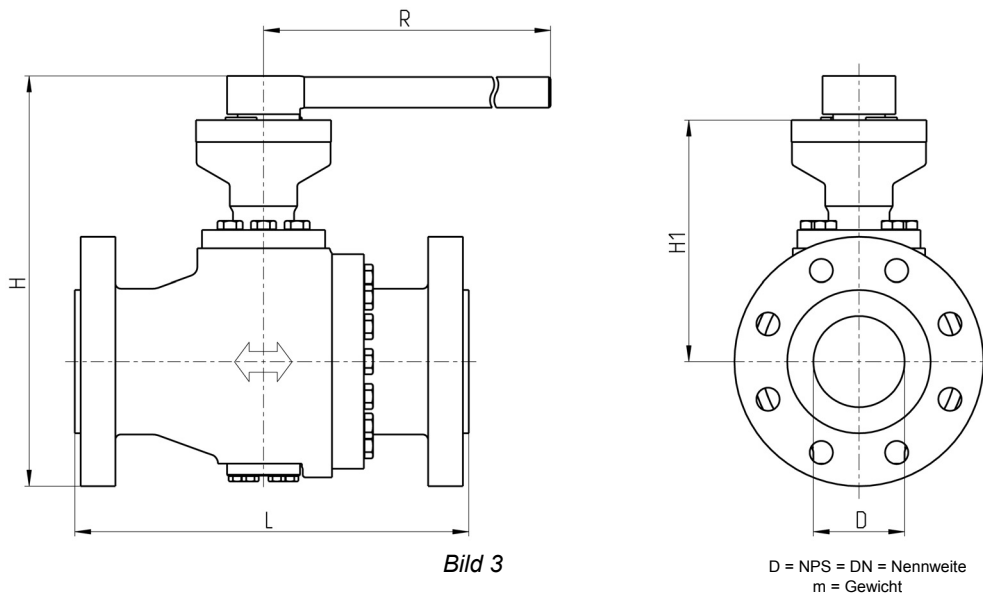

CLASS 150 - voller Durchgang

NPS [inch]	DN [mm]	H		H1		R		L ASME B16.10		Cv [gal/min]	m	
		[inch]	[mm]	[inch]	[mm]	[inch]	[mm]	[inch]	[mm]		[lbs]	[kg]
1	25	7.8	198	4.5	114	12	300	5	127	74	18	8
1¼	32	8.4	214	4.7	119	12	300	5.5	140	123	22	10
1½	40	10.4	264	6.1	156	18	450	6.5	165	191	31	14
2	50	12.6	319	8.1	205	18	450	7	178	298	59	27
2½	65	13.5	343	8.5	215	18	450	7.5	190	504	101	46
3	80	16.1	409	10	253	28	700	8	203	763	121	55
4	100	17	434	10.4	265	28	700	9	229	1192	158	72

Tab.2

CLASS 150 - reduzierter Durchgang

NPS [inch]	NPS-R [inch]	H		H1		R		L ASME B16.10		Cv [gal/min]	m	
		[inch]	[mm]	[inch]	[mm]	[inch]	[mm]	[inch]	[mm]		[lbs]	[kg]
1	¾	7.6	192	4.5	114	12	300	5	127	43	17	7.5
1¼	1	7.8	198	4.5	114	12	300	5.5	140	67	20	9
1½	1¼	8.4	214	4.7	119	12	300	6.5	165	110	25	12
2	1½	10.4	264	6.1	156	18	450	7	178	172	35	16
2½	2	12.6	319	8.1	205	18	450	7.5	190	268	68	31
3	2½	13.5	343	8.5	215	18	450	8	203	454	116	53
4	3	16.1	409	10	253	28	700	9	229	687	139	63

Tab.3



CLASS 300 - voller Durchgang

NPS [inch]	DN [mm]	H		H1		R		L ASME B16.10		Cv [gal/min]	m	
		[inch]	[mm]	[inch]	[mm]	[inch]	[mm]	[inch]	[mm]		[lbs]	[kg]
1	25	7.8	198	4.5	114	12	300	6.5	165	74	24	11
1¼	32	8.4	214	4.7	119	12	300	7	178	123	33	15
1½	40	10.4	264	6.1	156	18	450	7.5	190	191	51	23
2	50	11.0	279	6.5	165	18	450	8.5	216	298	64	29
2½	65	13.5	343	8.5	215	18	450	9.5	241	504	110	50
3	80	16.1	409	10	253	28	700	11.12	282	763	125	57
4	100	17	434	10.4	265	28	700	12	305	1192	165	75

Tab.4

CLASS 300 - reduzierter Durchgang

NPS [inch]	NPS-R [inch]	H		H1		R		L ASME B16.10		Cv [gal/min]	m	
		[inch]	[mm]	[inch]	[mm]	[inch]	[mm]	[inch]	[mm]		[lbs]	[kg]
1	¾	7.6	192	4.5	114	12	300	6.5	165	43	20	9
1¼	1	7.8	198	4.5	114	12	300	7	178	67	28	13
1½	1¼	8.4	214	4.7	119	12	300	7.5	190	110	38	17
2	1½	10.4	264	6.1	156	18	450	8.5	216	172	58	26
2½	2	12.6	319	8.1	205	18	450	9.5	241	268	73	33
3	2½	13.5	343	8.5	215	18	450	11.12	282	454	121	55
4	3	16.1	409	10	253	28	700	12	305	687	144	66

Tab.5

CLASS 600 - voller Durchgang

NPS [inch]	DN [mm]	H		H1		R		L ASME B16.10		Cv [gal/min]	m	
		[inch]	[mm]	[inch]	[mm]	[inch]	[mm]	[inch]	[mm]		[lbs]	[kg]
1	25	7.8	198	4.5	114	12	300	8.5	216	74	26	12
1¼	32	8.4	214	4.7	119	18	450	9	229	123	37	17
1½	40	10.4	264	6.1	156	18	450	9.5	241	191	64	29

Tab.6

CLASS 600 - reduzierter Durchgang

NPS [inch]	NPS-R [inch]	H		H1		R		L ASME B16.10		Cv [gal/min]	m	
		[inch]	[mm]	[inch]	[mm]	[inch]	[mm]	[inch]	[mm]		[lbs]	[kg]
1	¾	7.6	192	4.5	114	12	300	8.5	216	43	22	10
1¼	1	7.8	198	4.5	114	12	300	9	229	67	31	14
1½	1¼	8.4	214	4.7	119	18	450	9.5	241	110	44	20

Tab.7



CLASS 900 - Voller Durchgang

NPS [inch]	DN [mm]	H		H1		R		L ASME B16.10		Cv [gal/min]	m	
		[inch]	[mm]	[inch]	[mm]	[inch]	[mm]	[inch]	[mm]		[lbs]	[kg]
1	25	9.6	243	5.7	146	12	300	10.0	254	74	57	26
1¼	32	12.0	304	7.8	197	18	450	11	279	123	75	34
1½	40	12.3	313	7.8	197	18	450	12.0	305	191	81	37

Tab.8

CLASS 900 - Reduzierter Durchgang

NPS [inch]	NPS-R [inch]	H		H1		R		L ASME B16.10		Cv [gal/min]	m	
		[inch]	[mm]	[inch]	[mm]	[inch]	[mm]	[inch]	[mm]		[lbs]	[kg]
1	¾	9.2	233	5.7	146	12	300	10.0	254	43	57	26
1¼	1	11.8	299	7.8	197	18	450	11	279	67	73	33
1½	1¼	12.0	304	7.8	197	18	450	12.0	305	110	77	35

Tab.9

CLASS 1500 - Voller Durchgang

NPS [inch]	DN [mm]	H		H1		R		L ASME B16.10		Cv [gal/min]	m	
		[inch]	[mm]	[inch]	[mm]	[inch]	[mm]	[inch]	[mm]		[lbs]	[kg]
1	25	11.5	291	7.8	199	18	450	10.0	254	74	62	28
1½	40	13.9	352	8.9	226	28	700	15.1	384	191	132	60

Tab.10

CLASS 1500 - Reduzierter Durchgang

NPS [inch]	NPS-R [inch]	H		H1		R		L ASME B16.10		Cv [gal/min]	m	
		[inch]	[mm]	[inch]	[mm]	[inch]	[mm]	[inch]	[mm]		[lbs]	[kg]
1	¾	9.0	228	5.2	131	12	300	10.0	254	43	46	21
1½	1¼	12.0	305	7.4	189	18	450	12.0	305	110	73	33

Tab.11

PN 16 – PN 40

DN [mm]	H [mm]	H1 [mm]	R [mm]	L [mm] DIN EN 558		Kv [m ³ /h]	m [kg]	
				GR1	GR27		GR1	GR27
25	198	114	300	160	125	64	8	7
32	214	119	300	180	130	106	10	9
40	264	156	450	200	140	165	14	12
50	319	205	450	230	150	258	27	23
65	343	215	450	290	170	436	40	35
80	400	244	700	310	180	660	48	42
100	433	264	700	350	190	1031	63	54

Tab.12

PN 100

DN [mm]	H [mm]	H1 [mm]	R [mm]	L [mm] DIN EN 558		Kv [m ³ /h]	m [kg]	
				GR1	GR27		GR1	GR27
25	206	114	300	160	125	64	12	10
32	214	119	300	180	130	106	17	15
40	269	157	450	200	140	165	29	25

Tab.13

Weitere Abmessungen und Druckstufen auf Anfrage.



Bild 4

D = NPS = DN = Nennweite
m = Gewicht

CLASS 150 - voller Durchgang

NPS [inch]	DN [mm]	H		H1		H2		L1		D1		L ASME B16.10		Cv [gal/min]	m	
		[inch]	[mm]	[inch]	[mm]	[inch]	[mm]	[inch]	[mm]	[inch]	[mm]	[inch]	[mm]		[lbs]	[kg]
6	150	31	796	12	307	17	431	17	435	18	450	15.5	394	2682	308	140
8	200	40	1028	14	366	20	507	18	467	28	700	18	457	4767	594	270
10	250	47	1186	18	452	25	633	22	559	28	700	21	533	7746	792	360
12	300	51	1294	24	610	33	828	25	638	18	450	24	610	10727	1117	508
14	350	55	1390	24	600	35	898	28	724	18	450	27	686	14599	1593	724
16	400	62	1578	25	632	37	930	32	808	28	700	30	762	19069	2178	990
18	450	62	1576	28	710	40	1008	37	930	20	500	34	864	24134	3727	1694
20	500	67	1689	28	700	43	1090	39	978	20	500	36	914	29796	4759	2163
24	600	79	2009	34	863	49	1253	41	1035	28	700	42	1067	42906	7051	3205

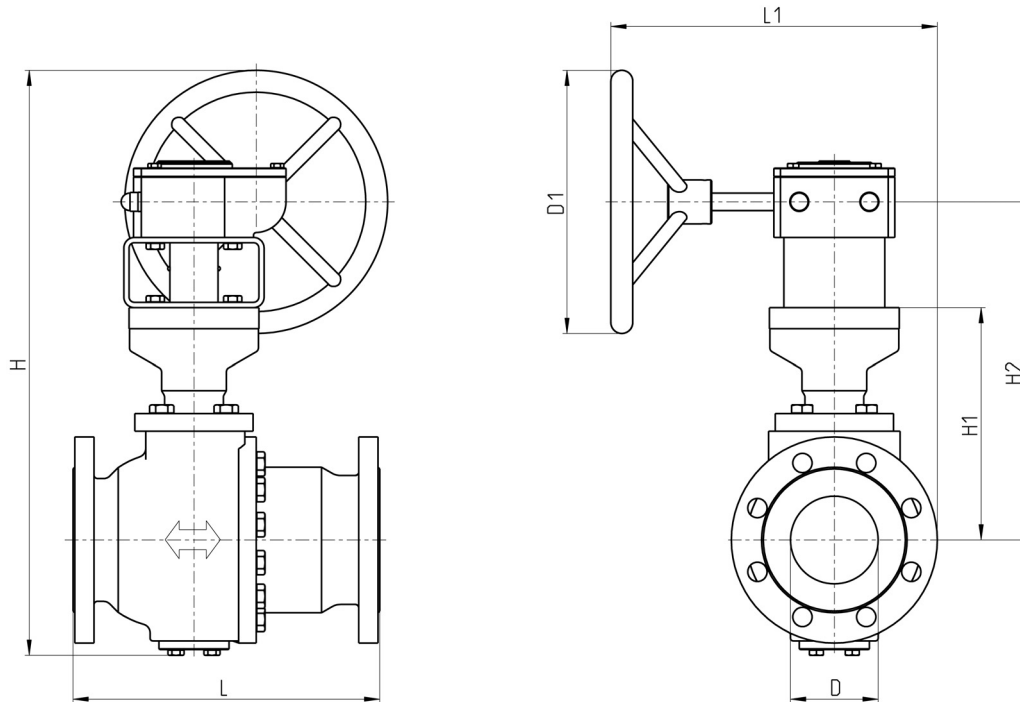
Tab.14

CLASS 150 - reduzierter Durchgang

NPS [inch]	NPS-R [inch]	H		H1		H2		L1		D1		L ASME B16.10		Cv [gal/min]	m	
		[inch]	[mm]	[inch]	[mm]	[inch]	[mm]	[inch]	[mm]	[inch]	[mm]	[inch]	[mm]		[lbs]	[kg]
6	5	28	703	10	264	15	388	15	373	14	350	15.5	394	1676	223	101
8	6	33	827	12	307	17	431	15	373	18	450	18	457	2414	339	154
10	8	42	1060	14	366	20	507	18	467	28	700	21	533	4291	559	254
12	10	48	1224	18	452	25	633	21	528	28	700	24	610	6972	894	407
14	12	52	1320	24	610	33	828	24	600	18	450	27	686	9654	1284	584
16	14	56	1421	24	600	35	898	28	699	18	450	30	762	13139	1832	833
18	16	63	1598	25	632	37	930	28	699	28	700	34	864	17162	2917	1326
20	18	64	1629	25	632	37	930	31	777	28	700	36	914	21720	4103	1865
24	20	69	1746	28	700	43	1090	39	979	20	500	42	1067	26816	5472	2487

Tab.15



CLASS 300 - voller Durchgang

NPS [inch]	DN [mm]	H		H1		H2		L1		D1		L ASME B16.10		Cv [gal/min]	m	
		[inch]	[mm]	[inch]	[mm]	[inch]	[mm]	[inch]	[mm]	[inch]	[mm]	[inch]	[mm]		[lbs]	[kg]
6	150	38	957	12	307	18	448	20	515	28	700	15.88	403	2682	383	174
8	200	45	1139	14	366	22	548	23	588	31	800	19.75	502	4767	608	277
10	250	50	1272	18	452	30	750	27	679	24	600	22.38	568	7746	938	427
12	300	56	1418	24	610	36	908	30	770	20	500	25.5	648	10727	1469	668
14	350	60	1532	24	600	39	990	35	888	20	500	30	762	14599	2275	1034
16	400	62	1571	25	632	40	1022	38	953	18	450	33	838	19069	3452	1569
18	450	75	1906	28	710	43	1100	39	985	35	900	36	914	24134	4352	1978
20	500	76	1927	28	700	43	1083	40	1019	36	914	39	991	29796	5656	2571
24	600	85	2160	34	863	49	1246	47	1202	36	914	45	1143	42906	9328	4240

Tab.16

CLASS 300 - reduzierter Durchgang

NPS [inch]	NPS-R [inch]	H		H1		H2		L1		D1		L ASME B16.10		Cv [gal/min]	m	
		[inch]	[mm]	[inch]	[mm]	[inch]	[mm]	[inch]	[mm]	[inch]	[mm]	[inch]	[mm]		[lbs]	[kg]
6	5	32	805	10.4	264	16	405	12	315	31	800	15.88	403	1676	319	145
8	6	38	957	12	307	18	448	20	515	28	700	19.75	502	2414	507	230
10	8	45	1139	14	366	22	548	23	588	31	800	22.38	568	4291	782	355
12	10	50	1272	18	452	30	750	27	679	24	600	25.5	648	6972	1224	556
14	12	56	1418	24	610	36	908	30	770	20	500	30	762	9654	1896	862
16	14	60	1532	24	600	39	990	35	888	20	500	33	838	13139	2877	1308
18	16	71	1796	25	632	40	1022	36	913	35	900	36	914	17162	3762	1710
20	18	75	1906	28	710	43	1100	39	985	35	900	39	991	21720	4714	2143
24	20	76	1927	28	700	43	1083	40	1019	36	914	45	1143	26816	7773	3533

Tab.17



CLASS 600 - Voller Durchgang

NPS [inch]	DN [mm]	H		H1		H2		L1		D1		L ASME B16.10		Cv [gal/min]	m	
		[inch]	[mm]	[inch]	[mm]	[inch]	[mm]	[inch]	[mm]	[inch]	[mm]	[inch]	[mm]		[lbs]	[kg]
2	50	13	329	8.1	205	14	346	18	461	10	250	11.5	292	298	110	50
2½	65	13.5	343	8.5	215	14	356	18	461	14	350	13	330	504	150	68
3	80	15.9	403	10	253	17	435	20	510	24	600	14	356	763	187	85
4	100	17	437	10.4	265	22	563	23	588	31	800	17	432	1192	330	150
6	150	37	947	15	378	20	519	25	639	20	500	22	559	2682	660	300
8	200	46	1163	19	471	26	653	28	720	24	600	26	660	4767	1320	600
10	250	51	1308	21	531	33	829	33	842	18	450	31	787	7746	2420	1100
12	300	58	1461	25	634	37	932	35	900	20	500	33	838	10727	3300	1500
14	350	73	1859	28	710	43	1100	35	898	36	914	35	889	14599	3960	1800
16	400	75	1912	28	722	44	1112	38	972	36	914	39	991	19069	4840	2200
18	450	82	2089	34	870	50	1260	39	1001	36	914	43	1092	24134	5896	2680
20	500	86	2186	37	940	52	1323	41	1038	36	914	47	1194	29796	6820	3100
24	600	90	2289	39	980	54	1363	43	1102	36	914	55	1397	42906	10780	4900

Tab. 18

CLASS 600 - Reduzierter Durchgang

NPS [inch]	NPS-R [inch]	H		H1		H2		L1		D1		L ASME B16.10		Cv [gal/min]	m	
		[inch]	[mm]	[inch]	[mm]	[inch]	[mm]	[inch]	[mm]	[inch]	[mm]	[inch]	[mm]		[lbs]	[kg]
2	1½	10.4	264	6.1	156	14	346	18	461	10	250	11.5	292	172	103	47
2½	2	13	329	8.1	205	14	346	18	461	10	250	13	330	268	127	58
3	2½	13.5	343	8.5	215	14	356	18	461	14	350	14	356	454	165	75
4	3	15.9	403	10	253	17	435	20	510	24	600	17	432	687	206	94
6	5	17	437	10.4	265	22	563	23	588	31	800	22	559	1676	380	173
8	6	37	947	15	378	20	519	25	639	20	500	26	660	2414	759	345
10	8	46	1163	19	471	26	653	28	720	24	600	31	787	4291	1518	690
12	10	51	1308	21	531	33	829	33	842	18	450	33	838	6972	2783	1265
14	12	58	1461	25	634	37	932	35	900	20	500	35	889	9654	3795	1725
16	14	73	1859	28	710	43	1100	35	898	36	914	39	991	13139	4554	2070
18	16	75	1912	28	722	44	1112	37	939	36	914	43	1092	17162	5566	2530
20	18	81	2060	34	870	50	1260	38	972	36	914	47	1194	21720	6472	2942
24	20	86	2186	37	940	52	1323	41	1038	36	914	55	1397	26816	7843	3565

Tab. 19



CLASS 900 - Voller Durchgang

NPS [inch]	DN [mm]	H		H1		H2		L1		D1		L ASME B16.10		Cv [gal/min]	m	
		[inch]	[mm]	[inch]	[mm]	[inch]	[mm]	[inch]	[mm]	[inch]	[mm]	[inch]	[mm]		[lbs]	[kg]
2	50	23.3	593	8.1	205	12.7	322	11.4	290	13.8	350	14.5	368	298	152	69
3	80	29.1	739	10.0	253	14.8	376	12.7	322	19.7	500	15.0	381	763	308	140
4	100	33.8	858	10.3	262	16.3	413	13.1	333	23.6	600	18.0	457	1192	374	170
6	150	47.4	1203	17.5	444	28.0	710	17.2	436	19.7	500	24.0	610	2682	1089	495
8	200	54.9	1395	18.7	476	31.6	802	19.4	493	23.6	600	29.0	737	4767	1573	715
10	250	60.2	1530	20.2	514	32.4	824	20.9	530	29.5	750	33.0	838	7746	2464	1120
12	300	65.0	1650	25.4	645	40.3	1024	23.6	600	19.7	500	38.0	965	10727	3696	1680
14	350	72.3	1836	26.2	666	42.0	1067	28.7	728	29.5	750	40.5	1029	14599	4840	2200
16	400	78.0	1980	27.0	685	42.7	1085	30.1	764	35.4	900	44.5	1130	19069	5500	2500
18	450	83.3	2115	28.4	722	44.3	1125	30.1	764	29.5	750	48.0	1219	24134	6930	3150

Tab.20

CLASS 900 - Reduzierter Durchgang

NPS [inch]	NPS-R [inch]	H		H1		H2		L1		D1		L ASME B16.10		Cv [gal/min]	m	
		[inch]	[mm]	[inch]	[mm]	[inch]	[mm]	[inch]	[mm]	[inch]	[mm]	[inch]	[mm]		[lbs]	[kg]
2½	2	23	593	8.1	205	12.7	322	11.4	290	13.8	350	16	419	268	174	79
3	2½	28.4	722	9.7	246	14	367	12	306	20	500	15	381	454	235	107
4	3	29.1	739	10.0	253	14.8	376	12.7	322	19.7	500	18	457	687	352	160
6	4	34	858	10.3	262	16.3	413	13.1	333	23.6	600	24	610	1676	493	224
8	6	47	1203	17.5	444	28.0	710	17.2	436	19.7	500	29	737	2414	1254	570
10	8	55	1395	18.7	476	31.6	802	19.4	493	23.6	600	33	838	4291	1756	798
12	10	60	1530	20.2	514	32.4	824	20.9	530	29.5	750	38	965	6972	2651	1205
14	12	65	1650	25.4	645	40.3	1024	23.6	600	19.7	500	41	1029	9654	3806	1730
16	14	72	1836	26.2	666	42.0	1067	28.7	728	29.5	750	44	1130	13139	5038	2290
18	16	78	1980	27.0	685	42.7	1085	30.1	764	35.4	900	48	1219	17162	5852	2660
20	18	83	2115	28.4	722	44.3	1125	30.1	764	29.5	750	52	1321	21720	7238	3290

Tab.21



CLASS 1500 - Voller Durchgang

NPS [inch]	DN [mm]	H		H1		H2		L1		D1		L ASME B16.10		Cv [gal/min]	m	
		[inch]	[mm]	[inch]	[mm]	[inch]	[mm]	[inch]	[mm]	[inch]	[mm]	[inch]	[mm]		[lbs]	[kg]
2	50	28.1	713	9.5	242	14.4	365	12.7	322	19.7	500	14.5	368	298	264	120
3	80	29.9	760	10.1	257	15.7	399	13.1	333	19.7	500	18.5	470	763	352	160
4	100	31.1	791	11.2	284	18.1	460	16.7	423	13.8	350	21.5	546	1192	616	280
6	150	46.4	1178	18.1	461	29.0	737	19.4	493	19.7	500	27.8	705	2682	1243	565
8	200	61.3	1557	18.7	476	31.7	805	20.9	530	35.4	900	32.8	832	4767	2156	980
10	250	62.6	1590	21.8	554	37.6	955	28.7	728	23.6	600	39.0	991	7746	4444	2020
12	300	70.7	1795	27.4	695	43.1	1096	30.1	764	23.6	600	44.5	1130	10727	4818	2190
14	350	71.8	1824	27.6	700	43.3	1101	30.1	764	23.6	600	49.5	1257	14599	5830	2650
16	400	75.2	1910	28.9	735	44.8	1137	30.1	764	23.6	600	54.5	1384	19069	11330	5150
18	450	82.2	2088	30.3	770	52.2	1327	40.8	1036	19.7	500	60.5	1537	24134	14498	6590

Tab.22

CLASS 1500 - Reduzierter Durchgang

NPS [inch]	NPS-R [inch]	H		H1		H2		L1		D1		L ASME B16.10		Cv [gal/min]	m	
		[inch]	[mm]	[inch]	[mm]	[inch]	[mm]	[inch]	[mm]	[inch]	[mm]	[inch]	[mm]		[lbs]	[kg]
2½	2	28.1	713	9.5	242	14.4	365	12.7	322	19.7	500	16	419	268	286	130
3	2½	28.9	735	10.1	257	15	380	13	322	20	500	19	470	454	361	164
4	3	29.9	760	10.1	257	15.7	399	13.1	333	19.7	500	21	546	687	400	182
6	4	31.1	791	11.2	284	18.1	460	16.7	423	13.8	350	28	705	1676	733	333
8	6	46.4	1178	18.1	461	29.0	737	19.4	493	19.7	500	33	832	2414	1463	665
10	8	61.3	1557	18.7	476	31.7	805	20.9	530	35.4	900	39	991	4291	2508	1140
12	10	62.6	1590	21.8	554	37.6	955	28.7	728	23.6	600	44	1130	6972	4884	2220
14	12	70.7	1795	27.4	695	43.1	1096	30.1	764	23.6	600	49	1257	9654	5258	2390
16	14	71.8	1824	27.6	700	43.3	1101	30.1	764	23.6	600	54	1384	13139	6336	2880
18	16	75.2	1910	28.9	735	44.8	1137	30.1	764	23.6	600	61	1537	17162	12078	5490
20	18	82.2	2088	30.3	770	52.2	1327	40.8	1036	19.7	500	66	1664	21720	15136	6880

Tab.23



PN 16

DN [mm]	H [mm]	H1 [mm]	H2 [mm]	L1 [mm]	D1 [mm]	L [mm] DIN EN 558		Kv [m³/h]	m [kg]	
						GR1	GR27		GR1	GR27
150	799	307	431	435	450	480	350	2320	117	101
200	1027	366	507	526	700	600	400	4124	192	167
250	1186	452	633	600	700	730	450	6701	307	267
300	1247	574	792	687	450	850	500	9279	441	384
350	1383	600	898	770	450	980	550	12629	630	547
400	1570	632	930	800	700	1100	762	16496	861	749
450	1578	710	1008	830	500	1200	-	20877	1723	-
500	1698	700	1090	987	500	1250	914	25775	2056	1788
600	2023	863	1253	1049	700	1450	-	37116	2964	-

Tab.24

PN 40

DN [mm]	H [mm]	H1 [mm]	H2 [mm]	L1 [mm]	D1 [mm]	L [mm] DIN EN 558		Kv [m³/h]	m [kg]	
						GR1	GR27		GR1	GR27
150	931	307	431	506	700	480	350	2320	151	132
200	1095	366	507	585	800	600	400	4124	240	209
250	1158	452	633	682	600	730	450	6701	371	322
300	1300	574	792	768	500	850	500	9279	580	505
350	1438	600	898	926	500	980	550	12629	899	782
400	1485	632	930	959	450	1100	762	16496	1364	1186
450	1808	710	1008	972	914	1200	-	20877	1978	-
500	1925	700	1090	1010	914	1250	914	25775	2236	1944
600	2155	863	1253	1190	914	1450	-	37116	3687	-

Tab.25

PN 100

DN [mm]	H [mm]	H1 [mm]	H2 [mm]	L1 [mm]	D1 [mm]	L [mm] DIN EN 558		Kv [m³/h]	m [kg]	
						GR1	GR27		GR1	GR27
50	329	205	470	480	250	230	150	258	43	38
65	343	215	484	487	350	290	170	436	59	51
80	403	253	585	542	600	310	180	660	74	64
100	437	265	735	645	800	350	190	1031	130	113
150	961	314	438	529	700	480	350	2320	261	227
200	1134	385	526	605	800	600	400	4124	522	454
250	1187	471	652	692	600	730	450	6701	957	832
300	1318	592	810	768	500	850	500	9279	1304	1134
350	1480	632	930	936	500	980	550	12629	1565	1361
400	1531	678	976	959	450	1100	762	16496	2200	1913
500	1947	722	1112	1010	914	1250	914	25775	3100	2696
600	2176	884	1274	1190	914	1450	-	37116	4900	4261

Tab.26

Weitere Abmessungen und Druckstufen auf Anfrage.



Dom-Baumaße



Bild 5

F	h		s		d3		d8	
	[mm]	[inch]	[mm]	[inch]	[mm]	[inch]	[mm]	[inch]
F07	22	0.9	12	0.5	70	2.8	17	0.7
F10	27	1.1	18	0.7	102	4	27	1.1
F12	38	1.5	32	1.3	125	4.9	40	1.6
F14	38	1.5	38	1.5	140	5.5	57	2
F16	48	1.9	44	1.7	165	6.5	68	2.7
F25	48	1.9	55	2.2	254	10	82	3.2
F35	94	3.7	65	2.6	356	14	98	3.9

Tab.27

Antriebsschnittstelle ISO 5211 voller Durchgang

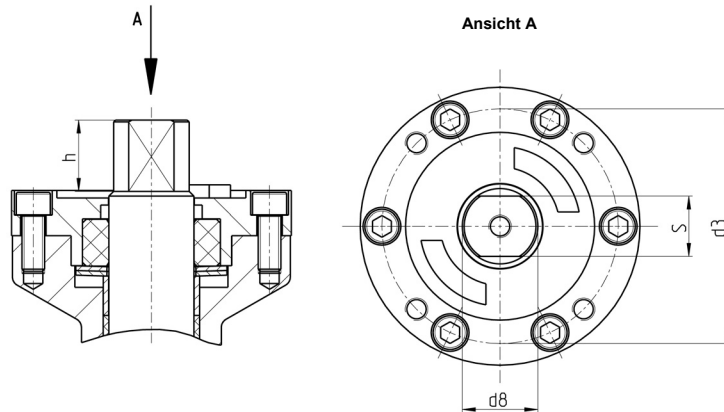
NPS [inch]	DN [mm]	CLASS / PN				
		150 / 16	300 / 40	600 / 100	900 / 160	1500 / 250
1	25	F07	F07	F07	F07	F10
1¼	32	F07	F10	F10	--	--
1½	40	F07	F10	F10	F10	F12
2	50	F10	F10	F10	F10	F12
2½	65	F10	F10	F10	--	--
3	80	F12	F12	F12	F12	F12
4	100	F12	F12	F12	F14	F16
6	150	F12	F14	F16	F25	F25
8	200	F14	F16	F25	F25*	F30*
10	250	F16	F25	F35	F35*	F35*
12	300	F16	F25	F35	F35*	F40*
14	350	F25	F35	F35*	F35*	F40*
16	400	F25	F35	F35*	F35*	F40*
18	450	F25	F35*	F40*	F40*	F48*
20	500	F35	F35*	F40*	--	--
24	600	F35	F40*	F48*	--	--

reduzierter Durchgang

NPS [inch]	NPS-R [inch]	CLASS				
		150	300	600	900	1500
1	¾	F07	F07	F07	F07	F10
1¼	1	F07	F07	F07	F07	F10
1½	1¼	F07	F10	F10	--	--
2	1½	F07	F10	F10	F10	F12
2½	2	F10	F10	F10	F10	F12
3	2½	F10	F10	F10	F12	F12
4	3	F12	F12	F12	F12	F12
6	4	F12	F12	F12	F14	F16
8	6	F12	F14	F16	F25	F25
10	8	F14	F16	F25	F25*	F30*
12	10	F16	F25	F35	F35*	F35*
14	12	F16	F25	F35	F35*	F40*
16	14	F25	F35	F35*	F35*	F40*
18	16	F25	F35	F35*	F35*	F40*
20	18	F25	F35	F35*	F40*	F48*
24	20	F35	F35*	F40*	--	--

* Passfeder

Tab.28



Druck- / Temperatur-Diagramm



Bild 6

Optionen

1) Sitzsystem mit geschütztem Federraum

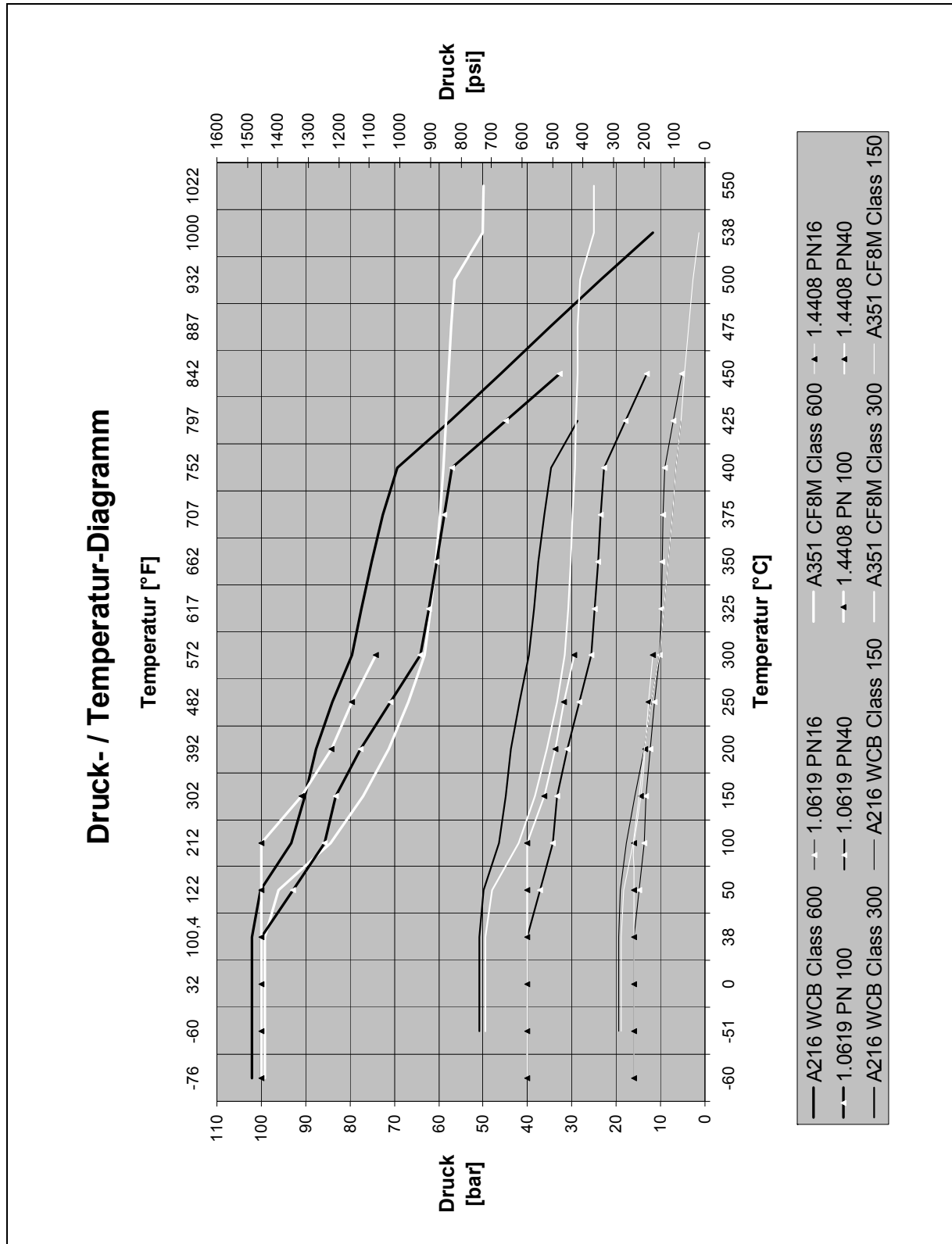

Bild 7

Der Bereich, in dem sich die zylindrischen Druckfedern (17) befinden, ist durch die Graphit basierende Dichtung (43) geschützt. Diese Dichtung verhindert das Eindringen von Feststoffen in den Federraum, gewährleistet aber trotzdem die Anfederung durch den Leitungsdruck.

2) Bi-direktionales Sitzsystem

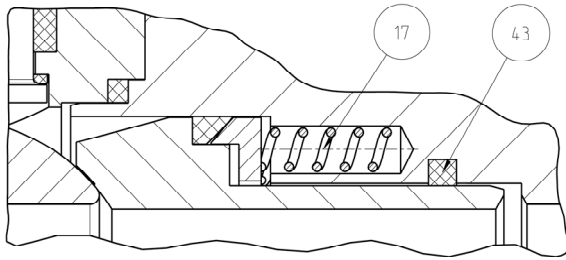

Bild 8

3) Hochdruck-Sitzsystem



Bild 9

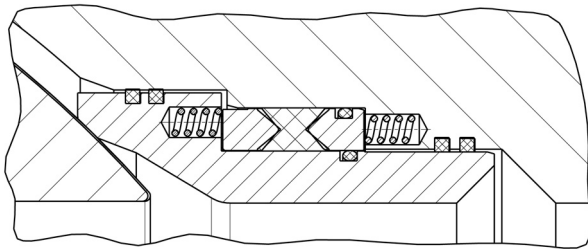

4) Kugelhahn mit einem uni-direktionalen Sitz

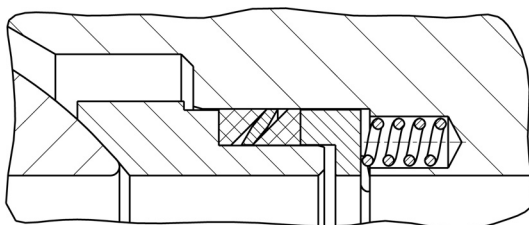

Bild 10

5) Einstellbare Packung

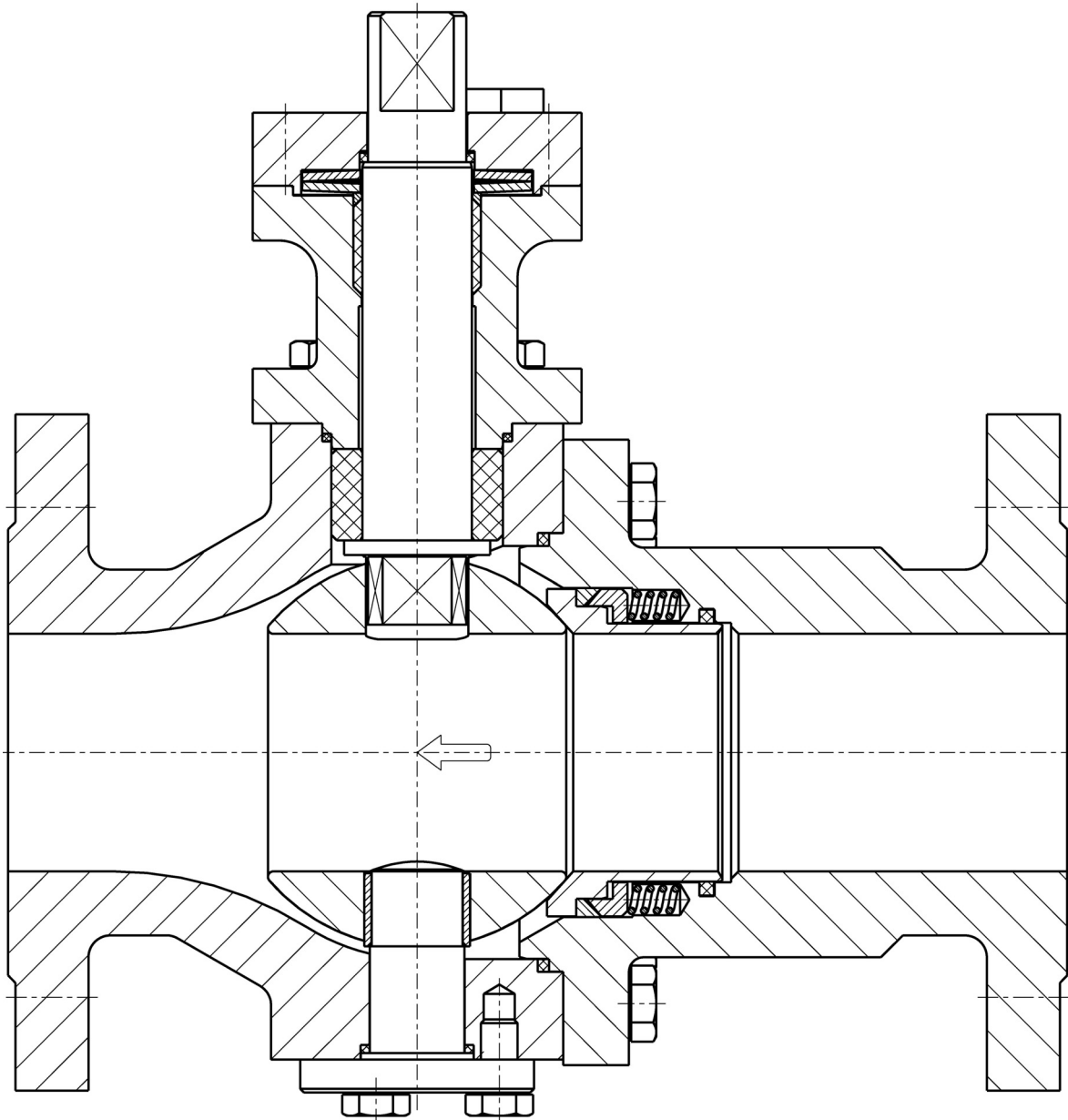

Bild 11

Die Packung kann zusätzlich mit Gewindestiften mit Innensechskant (46) ausgestattet werden. Durch anziehen dieser Stifte ist es möglich die Federkraft auf die Packung im Falle einer Leckage zu erhöhen.

6) Doppelte Stopfbuchse mit Schnüffelanschluss

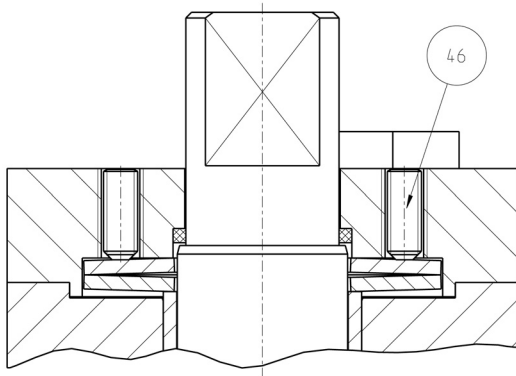

Bild 12

7) „Double Block and Bleed Port“ und/oder „Vent Port“

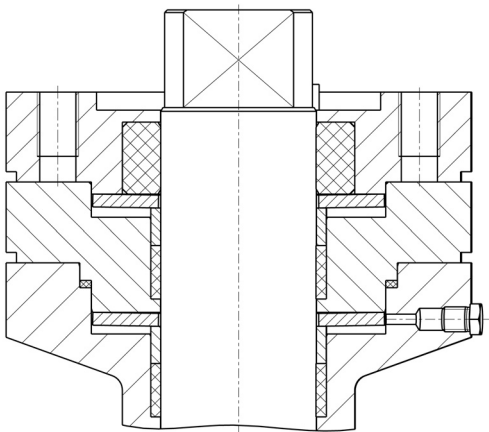

Bild 13

Bei Bedarf können die Armaturen mit „Bleed und Vent Ports“ ausgestattet werden.



8) Dreiteiliger Körper

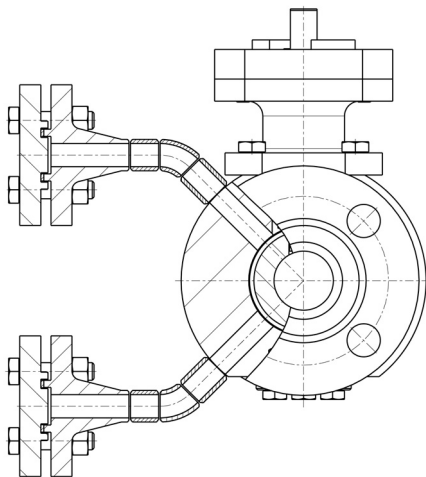
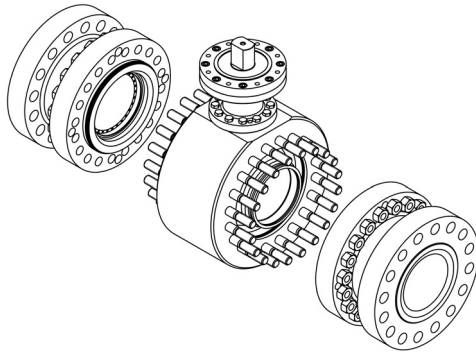

Die dreiteilige Gehäusekonstruktion für spezifische Anforderungen.

Bild 14

9) Kugelhahn mit Heizmantel

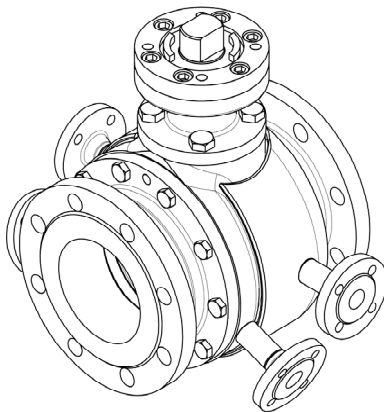

Bei Bedarf können die Armaturen mit Heizmantel ausgerüstet werden.

Bild 15

10) Kugelhahn mit Regelblende

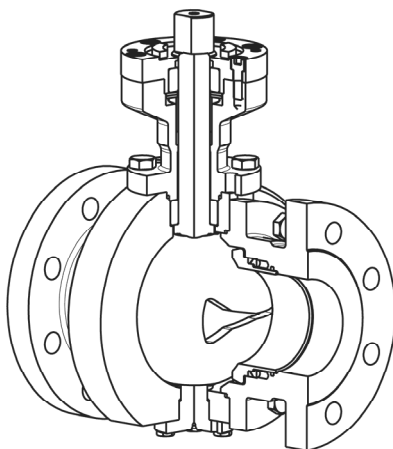

Bei Bedarf können die Armaturen mit Kugeln für geregelten Durchfluss ausgeführt werden.

Bild 16

11) Kugelhahn mit O-Ring Abdichtung

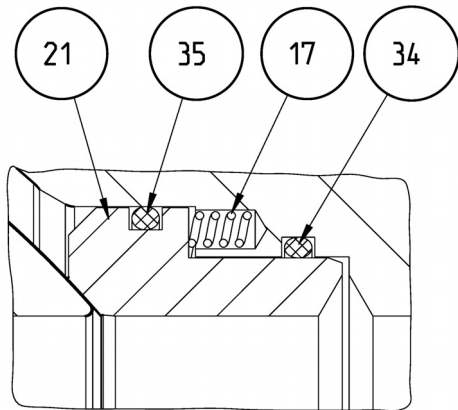

Bei Bedarf können die Armaturen zusätzlich mit O-Ringen (34, 35) abgedichtet werden.

Bild 17

12) Kugelhahn mit Tellerfeder-Anfederung

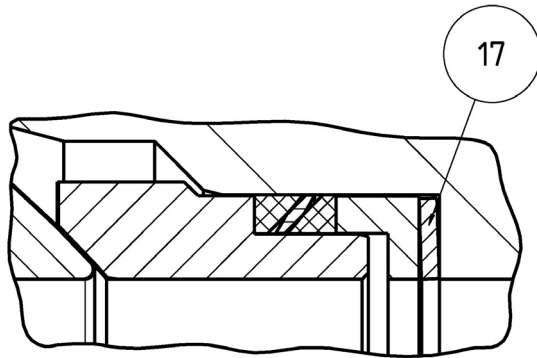

Anfederung der Armaturen kann bei Bedarf mit Tellerfedern (17) erfolgen.

Bild 18

13) Kugelhahn mit O-Ring Abdichtung am Sitzring

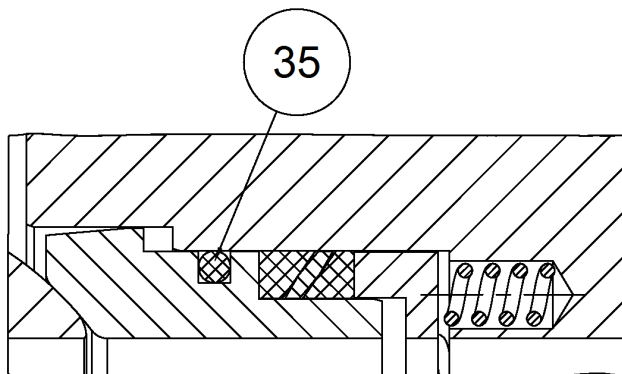

Bei Bedarf können die Armaturen zusätzlich mit einem O-Ring (35) am Sitzring abgedichtet werden.

Bild 18

Technische Änderungen vorbehalten.