

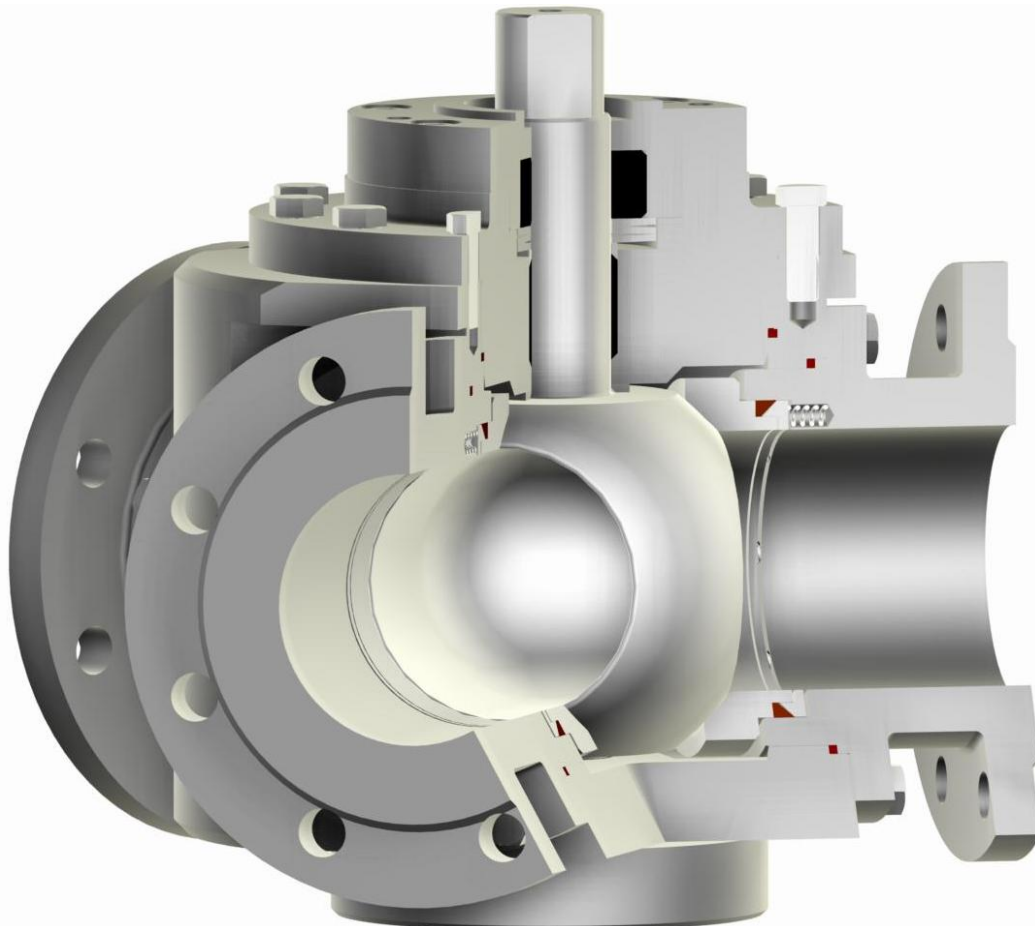

Three-Way Ball Valve Metal Seated Type 22-M



Design Characteristics

- ✓ Split body
- ✓ Ball with integral stem and twin bearings
- ✓ Live loaded stem packing
- ✓ Spring loaded seat system
- ✓ Fire Safe design optional
- ✓ 120° L-port

Design Standards

- ✓ EN 12516, EN 1983, ISO 5211, AD-2000
- ✓ ASME B 16.34, API 608

Range of Application

- ✓ Diameter ½" to 20" / DN 15 to 500
- ✓ Class 150 to 1500 / PN 10 to 250
- ✓ -20°F to +1000°F / -60°C to +550°C

Approvals

- ✓ "TA-Luft" certified for low fugitive emissions

Testing Standards

- ✓ EN 12266-1/2
- ✓ API 598



Main Parts

- 1 Body
- 2 Body End Connection
- 4 Retainer Ring
- 5 Ball with Stem
- 8 Gland Washer
- 10 Bearing Cover
- 12 Cover
- 13 Bearing Ring
- 14 Distance Disc
- 16 Plate Spring
- 17 Coil Spring
- 20 Sealing Ring
- 21 Seat Ring
- 23 Body Gasket
- 24 Stem Packing
- 25 Bearing Ring
- 27 Sealing Ring
- 228 Screw
- 29 Screw
- 30 Screw

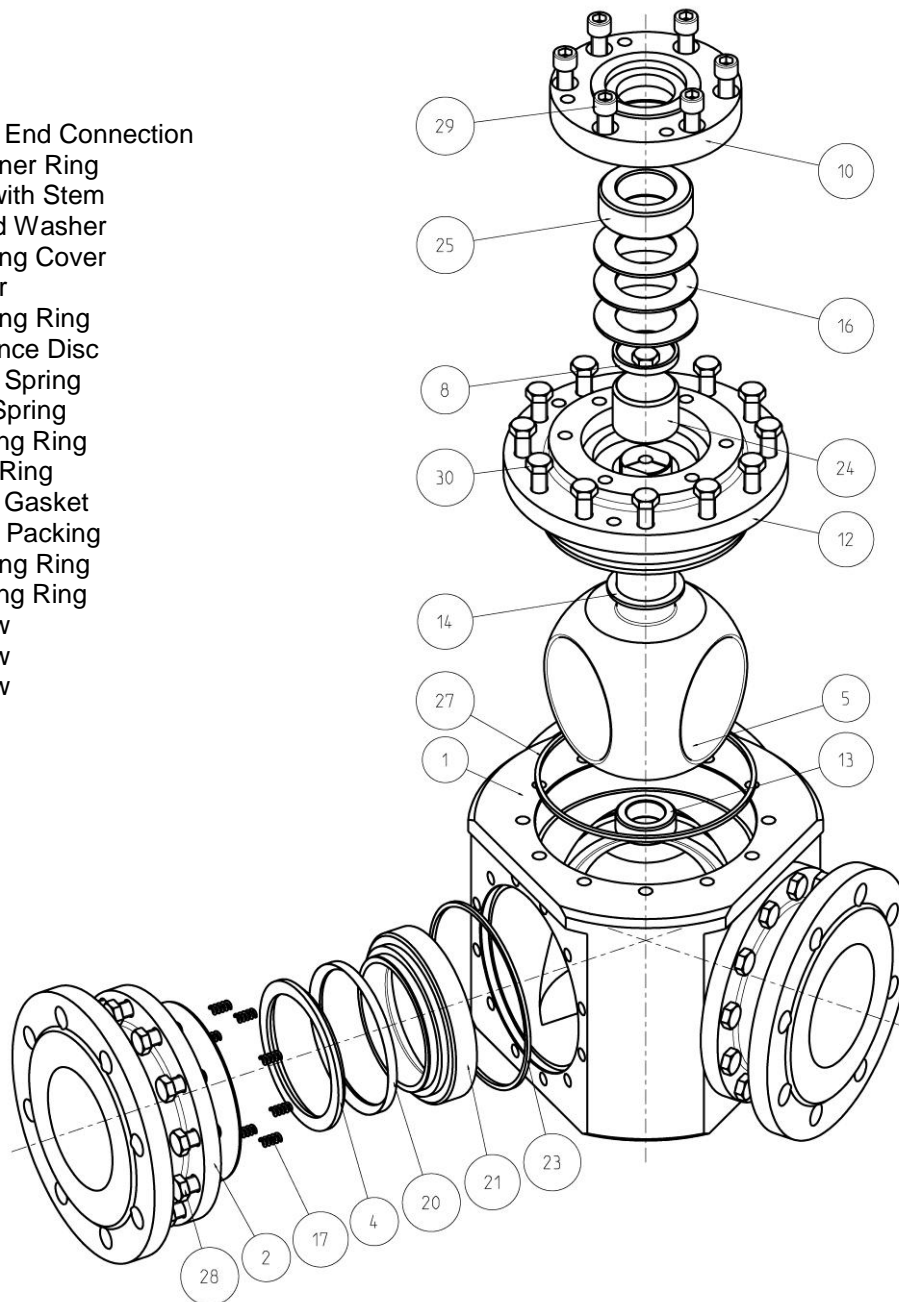

Fig.1

Description

This PERRIN ball valve has twin bearing ball with integral stem and split body housing. The spring loaded metallic seat system and live loaded stem packing also provide continuous tightness during short-term temperature and pressure changes.

The valve is equipped with an integral actuator mounting flange for actuator connection according to ISO 5211. Stem extensions, locking devices and actuators with accessories, can be attached without operating interruptions.

The ball valve has an antistatic design. The stem packing and sealings are "TA-Luft" certified for low fugitive emissions.



Parts List / Materials

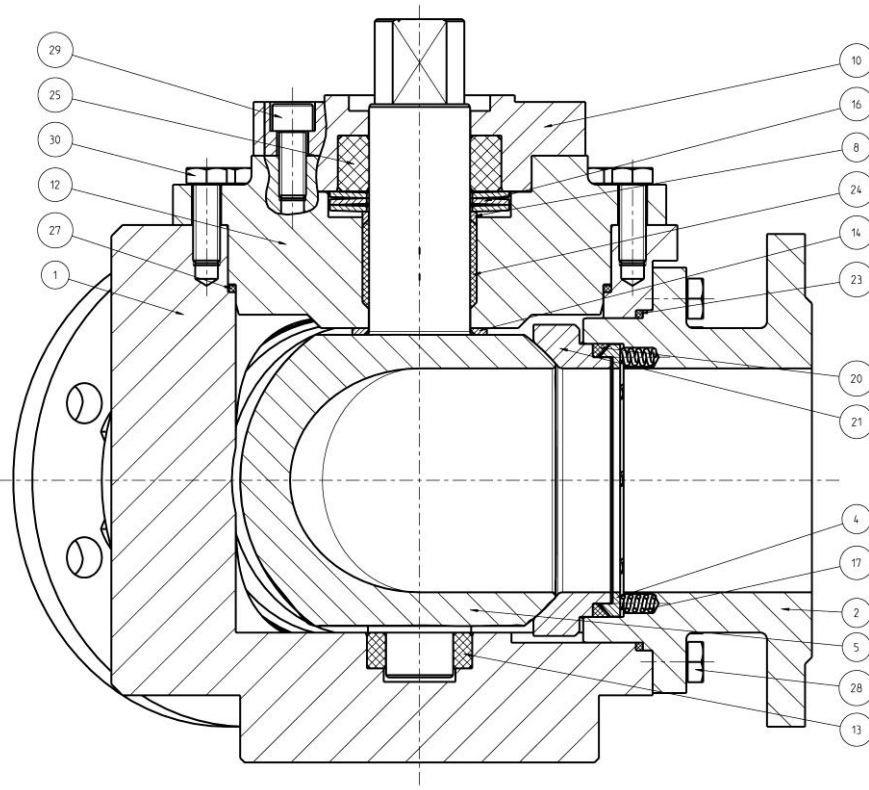

Fig.2

Item	Designation	ASME		DIN EN	
		-20°F up to +1000°F	-20°F up to +1000°F	-60°C up to +550°C	-10°C up to +450°C
1	Body	A351 CF8M	A216 WCB	1.4408 ¹⁾	1.0619
2	Body End Connection	Type 316 (up to 2")	A105 (up to 2")	1.4571 (up to 2")	1.0460 (up to 2")
4	Retainer Ring	Type 316	Type 316	1.4571	1.4571
5	Ball with Stem	Type 316 coated A351 CF8M coated	Type 316 coated A351 CF8M coated	1.4571 coated 1.4408 ¹⁾ coated	1.4571 coated 1.4408 ¹⁾ coated
8	Gland Washer	Type 316	Type 316	1.4571	1.4571
10	Bearing Cover	Type 316	A105	1.4571	1.0460
12	Cover	Type 316 A351 CF8M	A216 WCB A105	1.4571 1.4408 ¹⁾	1.0619 1.0460
13	Bearing Ring	Carbon-Antimony	Carbon-Antimony	Carbon-Antimony	Carbon-Antimony
14	Distance Disc	Type 316	Type 316	1.4571	1.4571
16	Plate Spring ²⁾	Type 301	AISI 6150	1.4310	1.8159
17	Coil Spring	Type 316	Type 316	1.4571	1.4571
20	Sealing Ring	Graphite	Graphite	Graphite	Graphite
21	Seat Ring	Type 316 coated	Type 316 coated	1.4571 coated	1.4571 coated
23	Body Gasket	Graphite	Graphite	Graphite	Graphite
24	Stem Packing				
25	Bearing Ring	Carbon	Carbon	Carbon	Carbon
27	Body Gasket	Graphite	Graphite	Graphite	Graphite
28	Screw	SS	SS	SS	SS
29	Screw	SS	SS	SS	SS
30	Screw	SS	SS	SS	SS

Tab.1

- 1) Temperature limitation 300°C [576°F] acc. to German technical rule AD-2000 W5 if intercrystalline corrosion resistant is required
 2) Material 2.4668 (Inconel 718) is generally required for operating temperature over 200°C [392°F]
 3) Materials for lower / higher temperature on request

Technical Data

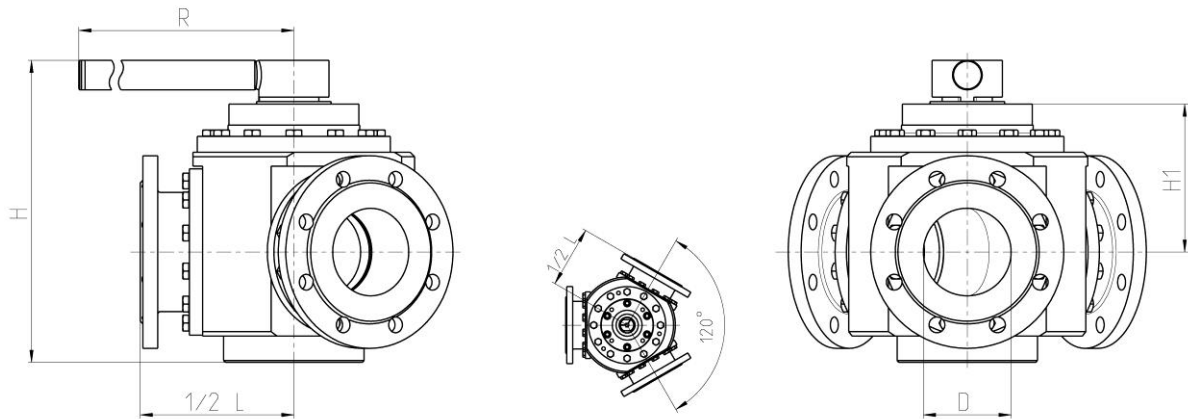

Fig.3

D = NPS = DN = Nominal Size
 m = Weight
 Cv; Kv = Flow Rate for L-Port

CLASS 150 - Full Bore

NPS [inch]	DN [mm]	H		H1		R		L Perrin Standard		Cv [gal/min]	m	
		[inch]	[mm]	[inch]	[mm]	[inch]	[mm]	[inch]	[mm]		[lbs]	[kg]
½	15	5,9	150	2,3	58	7	180	8	210	25	18	8
¾	20	6,4	163	2,8	70	7	180	9	230	45	22	10
1	25	6,9	175	2,9	74	12	300	9	230	71	31	14
1¼	32	7,3	185	3,1	80	12	300	10	260	114	48	22
1½	40	9,3	235	3,9	100	18	450	10	260	180	68	31
2	50	9,4	240	4,4	112	18	450	12	300	282	95	43
2½	65	9,6	244	4,7	119	18	450	11	290	477	134	61
3	80	11,9	301	6,1	156	31	800	12	310	724	183	83
4	100	12,7	323	6,6	167	31	800	14	350	1132	253	115

Tab.2

CLASS 150 - Reduced Bore

NPS [inch]	NPS-R [inch]	H		H1		R		L Perrin Standard		Cv [gal/min]	m	
		[inch]	[mm]	[inch]	[mm]	[inch]	[mm]	[inch]	[mm]		[lbs]	[kg]
¾	½	5,9	150	2,3	58	7	180	9	230	23	20	9
1	¾	6,4	163	2,8	70	7	180	9	230	41	25	12
1¼	1	6,9	175	2,9	74	12	300	10	260	63	35	16
1½	1¼	7,3	185	3,1	80	12	300	10	260	103	56	25
2	1½	9,3	235	3,9	100	18	450	12	300	162	78	36
2½	2	9,4	240	4,4	112	18	450	11	290	254	109	49
3	2½	9,6	244	4,7	119	18	450	12	310	430	154	70
4	3	11,9	301	6,1	156	31	800	14	350	651	210	95

Tab.3



CLASS 300 - Full Bore

NPS [inch]	DN [mm]	H		H1		R		L Perrin Standard		Cv [gal/min]	m	
		[inch]	[mm]	[inch]	[mm]	[inch]	[mm]	[inch]	[mm]		[lbs]	[kg]
½	15	5,9	150	2,3	58	7	180	8	210	25	26	12
¾	20	6,4	163	2,8	70	7	180	9	230	45	44	20
1	25	6,9	175	2,9	74	12	300	9	230	71	46	21
1¼	32	7,3	185	3,1	80	12	300	10	260	114	53	24
1½	40	9,3	235	3,9	100	18	450	10	260	180	68	31
2	50	9,4	240	4,4	112	18	450	12	300	282	108	49
2½	65	9,6	244	4,7	119	18	450	13	340	477	174	79
3	80	11,9	301	6,1	156	31	800	15	380	724	209	95
4	100	12,7	323	6,6	167	31	800	17	430	1132	264	120

Tab.4

CLASS 300 - Reduced Bore

NPS [inch]	NPS-R [inch]	H		H1		R		L Perrin Standard		Cv [gal/min]	m	
		[inch]	[mm]	[inch]	[mm]	[inch]	[mm]	[inch]	[mm]		[lbs]	[kg]
¾	½	5,9	150	2,3	58	7	180	9	230	23	41	18,5
1	¾	6,4	163	2,8	70	7	180	9	230	41	43	19,5
1¼	1	6,9	175	2,9	74	12	300	10	260	63	48	22
1½	1¼	7,3	185	3,1	80	12	300	10	260	103	64	29
2	1½	9,3	235	3,9	100	18	450	12	300	162	99	45
2½	2	9,4	240	4,4	112	18	450	13	340	254	161	73
3	2½	9,6	244	4,7	119	18	450	15	380	430	194	88
4	3	11,9	301	6,1	156	31	800	17	430	651	244	111

Tab.5



PN 16

DN [mm]	H [mm]	H1 [mm]	R [mm]	L [mm] Perrin Standard	Kv [m ³ /h]	m [kg]
15	150	58	180	210	22	8
20	163	70	180	230	39	10
25	175	74	300	230	61	14
32	185	80	300	260	99	22
40	235	100	450	260	156	31
50	240	112	450	300	244	43
65	244	119	450	290	413	61
80	301	156	800	310	626	83
100	323	167	800	350	979	115

Tab.6

PN 40

DN [mm]	H [mm]	H1 [mm]	R [mm]	L [mm] Perrin Standard	Kv [m ³ /h]	m [kg]
15	150	58	180	210	22	12
20	163	70	180	230	39	20
25	175	74	300	230	61	21
32	185	80	300	260	99	24
40	235	100	450	260	156	31
50	240	112	450	300	244	49
65	244	119	450	340	413	79
80	301	156	800	380	626	95
100	323	167	800	430	979	120

Tab.7

Other dimensions and pressure classes on request.

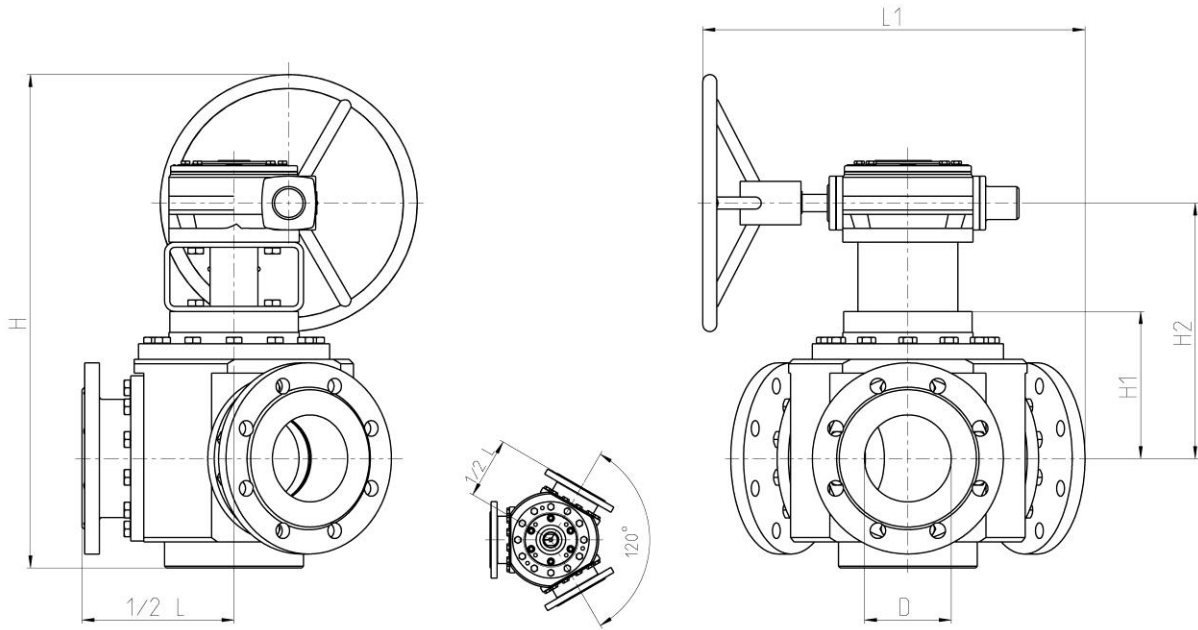

Fig.4

D = NPS = DN = Nominal Size
 m = Weight
 Cv; Kv = Flow Rate for L-Port

CLASS 150 - Full Bore

NPS [inch]	DN [mm]	H		H1		H2		L1		D1		L Perrin Standard		Cv [gal/min]	m	
		[inch]	[mm]	[inch]	[mm]	[inch]	[mm]	[inch]	[mm]	[inch]	[mm]	[inch]	[mm]		[lbs]	[kg]
6	150	32	821	8	201	13	331	20	515	28	700	19	480	2548	638	290
8	200	35	877	10	266	18	456	23	588	20	500	24	600	4528	1188	540
10	250	42	1057	11	284	20	504	29	725	28	700	35	900	7358	1936	880

Tab.8

CLASS 150 - Reduced Bore

NPS [inch]	NPS-R [inch]	H		H1		H2		L1		D1		L Perrin Standard		Cv [gal/min]	m	
		[inch]	[mm]	[inch]	[mm]	[inch]	[mm]	[inch]	[mm]	[inch]	[mm]	[inch]	[mm]		[lbs]	[kg]
6	5	27	687	7	167	12	297	19	492	20	500	19	480	1592	592	269
8	6	34	852	8	201	13	331	20	515	28	700	24	600	2293	1126	512
10	8	36	909	10	266	18	456	23	588	20	500	35	900	4075	1793	815
12	10	43	1095	11	284	20	504	29	725	28	700	49	1250	6622	1916	871

Tab.9



CLASS 300 - Full Bore

NPS [inch]	DN [mm]	H		H1		H2		L1		D1		L Perrin Standard		Cv [gal/min]	m	
		[inch]	[mm]	[inch]	[mm]	[inch]	[mm]	[inch]	[mm]	[inch]	[mm]	[inch]	[mm]		[lbs]	[kg]
6	150	33	840	12	307	17	431	24	610	20	500	22	550	2548	836	380
8	200	39	998	14	366	20	507	31	790	24	600	26	650	4528	1397	635
10	250	49	1255	18	452	25	633	28	718	31	800	35	900	7358	2079	945

Tab.10

CLASS 300 - Reduced Bore

NPS [inch]	NPS-R [inch]	H		H1		H2		L1		D1		L Perrin Standard		Cv [gal/min]	m	
		[inch]	[mm]	[inch]	[mm]	[inch]	[mm]	[inch]	[mm]	[inch]	[mm]	[inch]	[mm]		[lbs]	[kg]
6	5	31	796	7	167	13	337	22	560	24	600	22	550	1592	774	352
8	6	34	872	12	307	17	431	24	610	20	500	26	650	2293	1294	588
10	8	41	1029	14	366	20	507	31	790	24	600	35	900	4075	1925	875
12	10	51	1293	18	452	25	633	28	718	31	800	49	1250	6622	2611	1187

Tab.11

PN 16

DN [mm]	H [mm]	H1 [mm]	H2 [mm]	L1 [mm]	D1 [mm]	L [mm] Perrin Standard	Kv [m ³ /h]	m [kg]
150	824	201	331	515	700	480	2204	290
200	1026	266	456	588	800	600	3917	540
250	1007	284	504	679	600	900	6365	880

Tab.12

PN 40

DN [mm]	H [mm]	H1 [mm]	H2 [mm]	L1 [mm]	D1 [mm]	L [mm] Perrin Standard	Kv [m ³ /h]	m [kg]
150	924	307	431	515	700	550	2204	380
200	1077	366	507	588	800	650	3917	635
250	1136	452	633	679	600	900	6365	945

Tab.13

Other dimensions and pressure classes on request.

Top Works

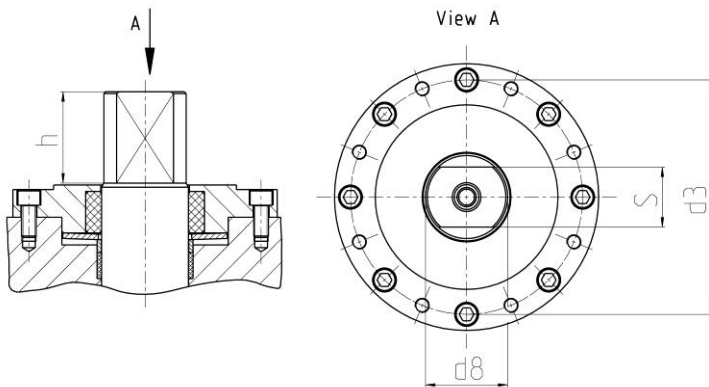

Fig.5

F	h		s		d3		d8	
	[mm]	[inch]	[mm]	[inch]	[mm]	[inch]	[mm]	[inch]
F07	22	0,9	12	0,5	70	2,8	17	0,7
F10	27	1,1	18	0,7	102	4	27	1,1
F12	38	1,5	32	1,3	125	4,9	40	1,6
F14	38	1,5	38	1,5	140	5,5	57	2
F16	48	1,9	44	1,7	165	6,5	68	2,7
F25	48	1,9	55	2,2	254	10	82	3,2
F35	94	3,7	65	2,6	356	14	98	3,9

Tab.14

Actuator-Connection ISO 5211 Full Bore

Reduced Bore

NPS [inch]	DN [mm]	CLASS / PN		NPS [inch]	NPS-R [inch]	CLASS	
		150 / 16	300 / 40			150	300
½	15	F07	F07	½	-	-	-
¾	20	F07	F07	¾	-	-	-
1	25	F07	F07	1	¾	F07	F07
1¼	32	F07	F10	1¼	1	F07	F07
1½	40	F07	F10	1½	1¼	F07	F10
2	50	F10	F10	2	1½	F07	F10
2½	65	F10	F10	2½	2	F10	F10
3	80	F12	F12	3	2½	F10	F12
4	100	F12	F12	4	3	F12	F12
6	150	F12	F14	6	4	F12	F14
8	200	F14	F16	8	6	F12	F14
10	250	F16	F25	10	8	F14	F16
12	300	F16	F25	12	10	F16	F25
14	350	F25	F35*	14	12	F16	F25
16	400	F25*	F35*	16	14	F25	F35*
20	500	F35*	F35*	20	16	F25*	F35*

* Feather Keyway

Tab.15



Pressure / Temperature Diagram

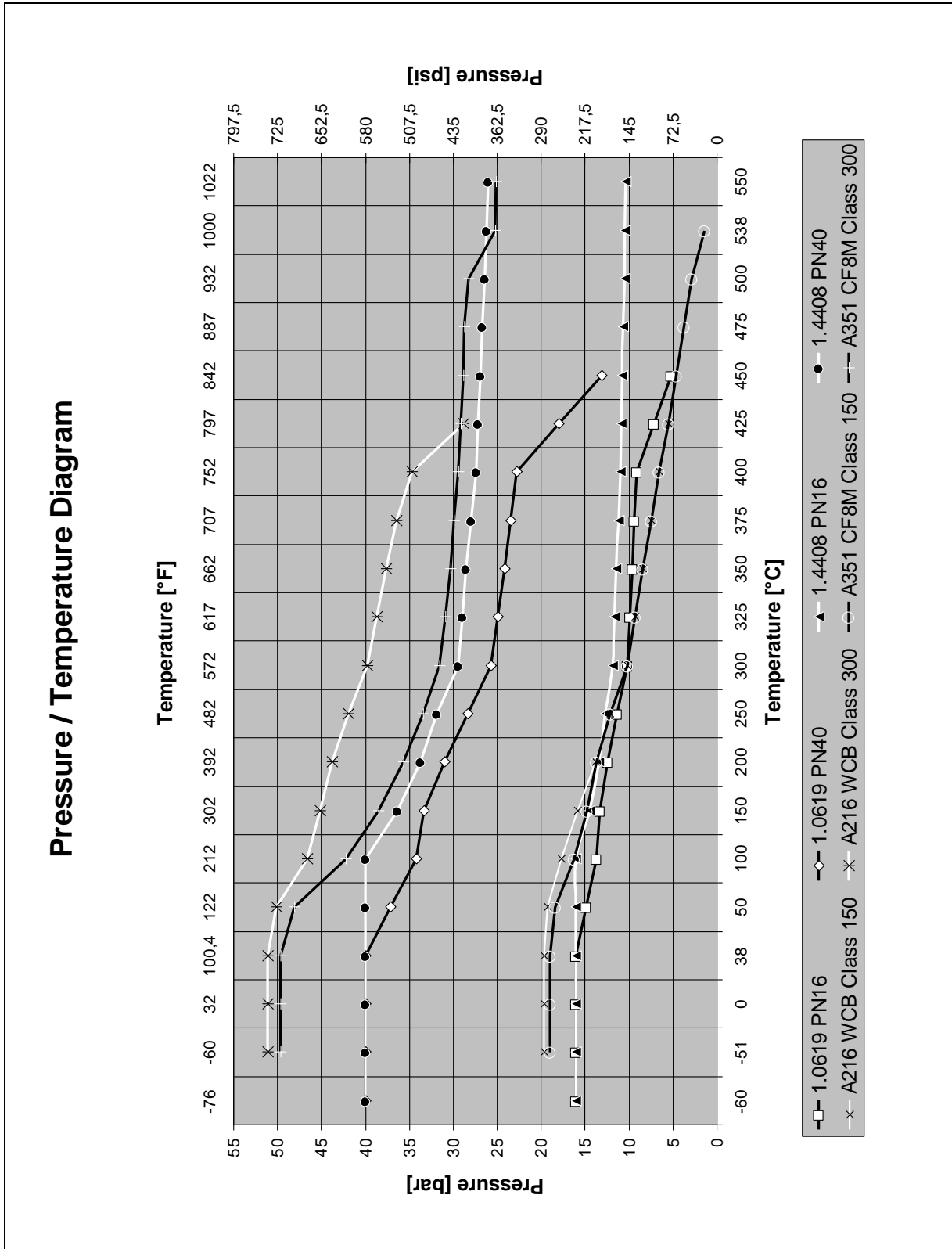

Fig.6

Options

1) Seat system with protected spring area

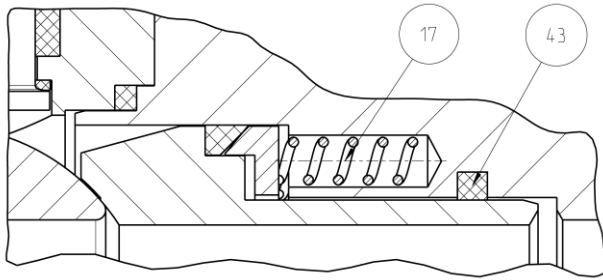

Fig.7

The area where the springs (17) are located is protected by graphite-based seal (43). This seal prevents material from entering the spring area or recess but allow the spring chamber to be energized by line pressure.

2) Adjustable stem packing

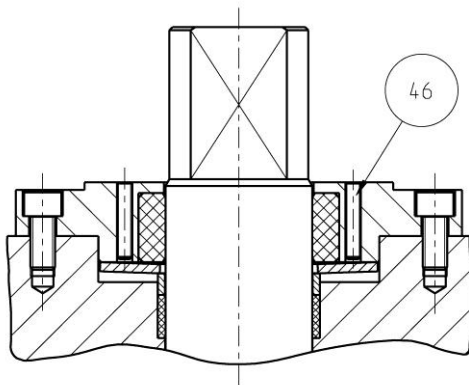

Fig.8

Additionally the live loaded stem packing may be equipped with hexagon socket screws (46). To fasten these screws it is possible to increase the spring force on the packing in the event of leakage.

3) Double-stage gland packing with sniffing connection

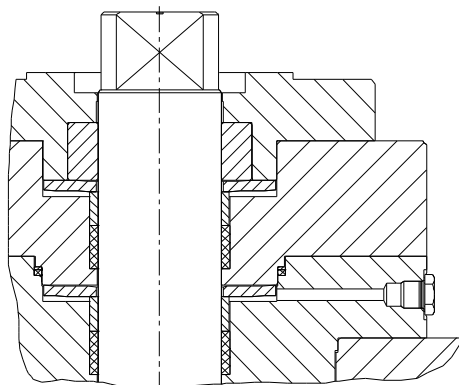

Fig.9

4) Ball positions

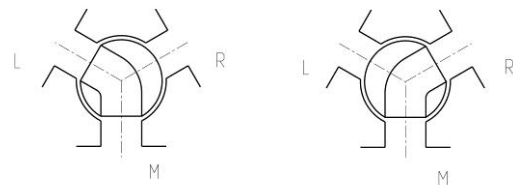

Fig.10

Technical modifications are reserved.

